

# AVR Manual

AVR(AUTOMATIC VOLTAGE REGULATOR)

MODEL : FC2

## ◆ Contents ◆

1. Introduction .....	3
2. Feature .....	3
3. Specification .....	3
4. Working condition .....	4
5. Structure .....	4
6. Regulator .....	4
7. Connection .....	4
8. Check for operation .....	5
9. Adjusting .....	6
10. System start up .....	7
11. AVR operation test .....	7
12. Frequency-output voltage characteristic curve according to frequency system .....	8
13. Trouble cause and solution. ....	8



Engine, Regulator Products

**EGCON Co., Ltd**

<http://www.egcon.co.kr> sales@egcon.co.kr

TEL: +82) 032-677-9806 FAX: +82) 032-677-9807

## Notice

1. To use this product safely, please do understand operation manuals before use.
2. To prevent personal injury or equipment damage, matters that require attention must be followed.
3. The matters that require attention are "Warning" and "Caution", the meaning is as follows.



### Warning

Incorrect use could cause injury or death.



### Caution

Incorrect use could cause personal injury or equipment damage.

4. The symbols in operation manuals mean as follows



Be careful!, it could damage equipment.



Be careful!, it could cause electric shock.

5. Keep operation manuals close to the product.



### Warning

1. Do not any wire works when the power is on or the main cable is operated. It could cause electrocution or fire.
2. Do not assemble even if the power is off. The charged current of inside equipment could cause electric shock.
3. Do not touch with a wet hand. It could cause electric shock.
4. Do not touch when wires are damaged. It could cause electric shock.
5. Do set up an earthing device to prevent electric shock.



### Caution

1. Use rated power to prevent equipment damage or fire.
2. Keep foreign substances out to prevent short circuit or fire.
3. To prevent equipment damage or fire, connect a load appropriate to the input or output capacity.
4. Connecting a random wire could cause equipment damage or fire.
5. Incorrect use could cause personal injury or the product and connected products damage. Only qualified technicians and operators should use this device.
6. A test using high voltage such as a voltage withstand test or an insulation resistance test could cause equipment damage. So separate them before testing.
7. Use a rated fuse and wire to prevent fire. .
8. This device is attached to a generator that vibrates a lot. So fasten it tight
9. Check loose part before installation.

## 1. Introduction

AVR-FC2 is a voltage regulator.

## 2. Feature

- 2.1. Available for low exciter field resistance.
- 2.2. Excited early. (When residual voltage is left)
- 2.3. Less trouble (no relay and no transformer)
- 2.4. Durable under dust, damp and vibration( SILICON MOLDING )
- 2.5. Single phase radio wave control using SCR
- 2.6. Available to get input power(220Vac/50Hz/60Hz/125Hz) from PMG(permanent magnetic generator) or assisting winding
- 2.7. Available to get 220Vac or 380Vac sensing voltage
- 2.8. Protecting AVR and generator by controlling low frequency.
- 2.9. Over output voltage protector setting.
- 2.10. Stability setting switch for large and small capacity generator
- 2.11. Substitute model for AVR126

## 3. Specification

- 3.1. Maximum continuous output :125Vdc, 6A(750W)
- 3.2. Maximum output for 10secs (240Vac input) : 200Vdc, 10A(2KW)
- 3.3. Power input: Single phase 190–277Vac  $\pm 10\%$ , 50/60/125 Hz, 1.2KVA
- 3.4. Sensing input: Single phase 180–277V ac , 50/60Hz. 8VA
- 3.5. Exciter field resistance: 18.3–100 $\Omega$
- 3.6. AC POWER input(terminal 3.4): Single phase 190–277 Vac  $\pm 10$ , 60 Hz, 650 VA
- 3.7. External voltage control resistor: 2 K $\Omega$  , 2 W
- 3.8. Voltage build-up: raised by residual voltage(min 5 Vac) of the generator
- 3.9. Voltage stability : Less than  $\pm 1\%$  between no load to full load
- 3.10. Answering time: Within 1.5cycle while  $\pm 5\%$  sensing voltage changes.
- 3.11. Available for Brushless, 50 / 60 Hz generator
- 3.12. Low-frequency protection: It is set to work 47Hz on 50Hz, 57Hz on 60Hz
- 3.13. Over excitation protection: When exciter field voltage goes over 75–125Vdc, AVR stops outputting for a while. After detecting over input voltage, it outputs for 10 secs. But delayed time is getting shorter as voltage goes higher. When output goes over 240Vdc, AVR shut off output instantly.
- 3.14. Power consumption: max. 35W
- 3.15. Fixing bolt: Smaller than M5.
- 3.16. Size: D200 W140 – H36(mm), Cut-out: D190 W90(mm)
- 3.17. Weight: 1.35Kg, 1.5Kg(including a box)
- 3.18. High current-limiting fuse: 250Vac, 6.3A. 5 $\Phi$ -20L

### 4. Working condition

- 4.1. Operating temperature: -10° ~ 40°C
- 4.2. Storage temperature : -24° ~ 45°C
- 4.3. Relative humidity: 0% ~ 90% with no condensation
- 4.4. Vibration : Amplitude-0.35mm, Frequency-0~30Hz
- 4.5. Max operating altitude: 3,000m
- 4.6. Max storage altitude: 4,500m m
- 4.7. Indoor setting up unaffected by dust and salt

### 5. Structure

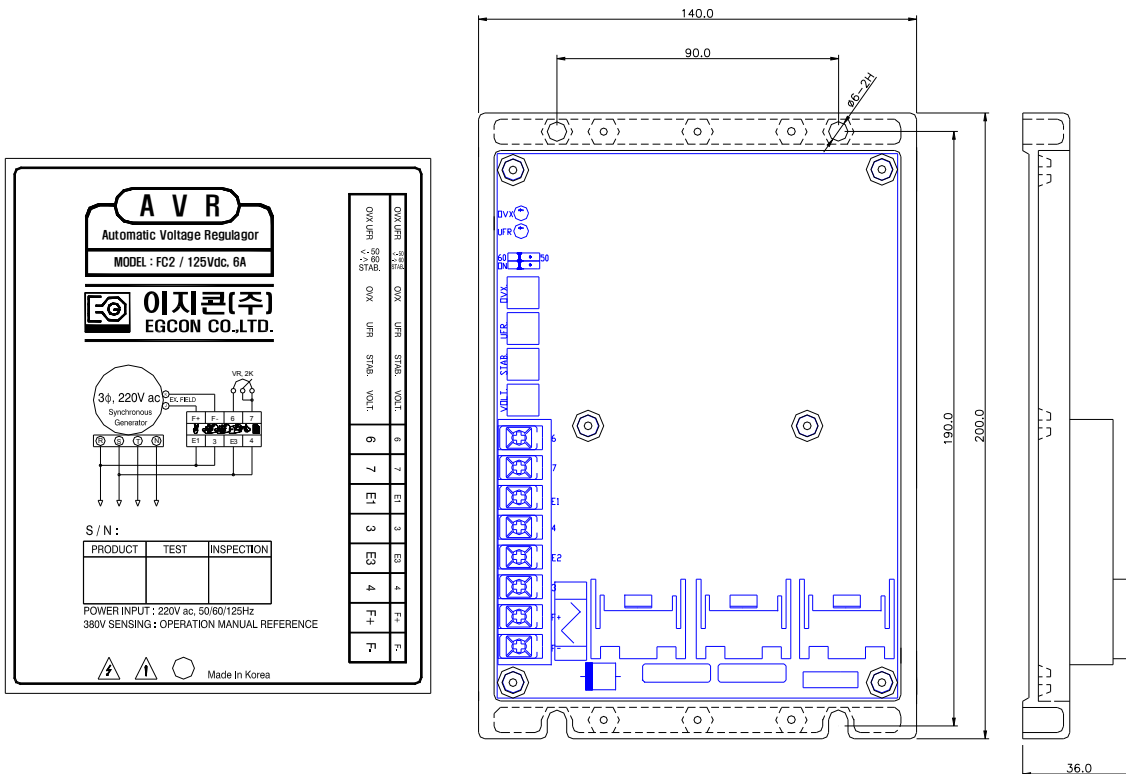

### 6. Variable resistance

- 6.1. VOLT. : Variable resistance for setting voltage
- 6.2. STAB. : Answering speed regulation resistance
- 6.3. UFR. : Low-frequency protector resistance ( preset in a factory )
- 6.4. OVX. : Over output voltage breaker regulation resistance
- 6.5. STAB-ON :Voltage stabilizing switch
- 6.6. 60Hz/50Hz : Frequency system switch

### 7. Connection

- 7.1. After checking the AVR is suitable with generator exciter capacity, connect wires like below [Drawing1].
- 7.2. When using the external voltage control resistor, connect it to the terminal 6,7. Otherwise short terminal 6, 7.
- 7.3. Connect EX. field to the terminal F+, F- . Conform with their electrode
- 7.4. Supply AC220V to the terminal3, 4

7.5. Connecting a 380V wire after removing the jumper like below [Picture1]

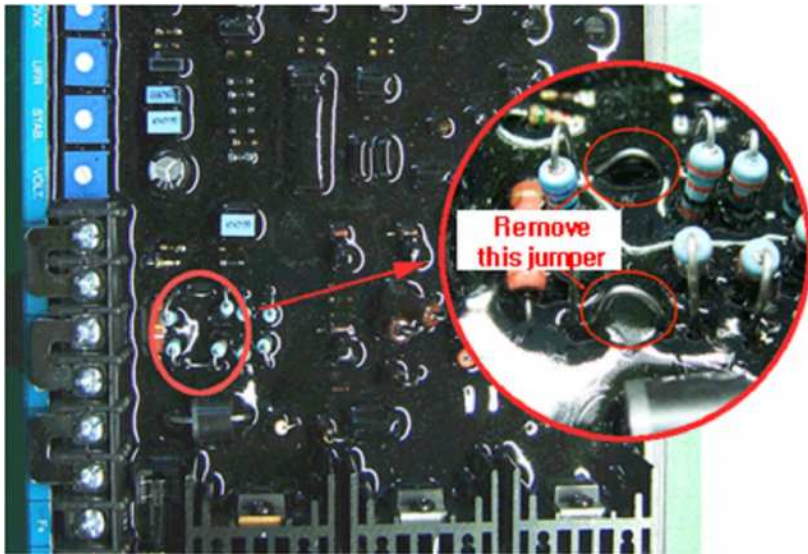

[ Picture 1 ]

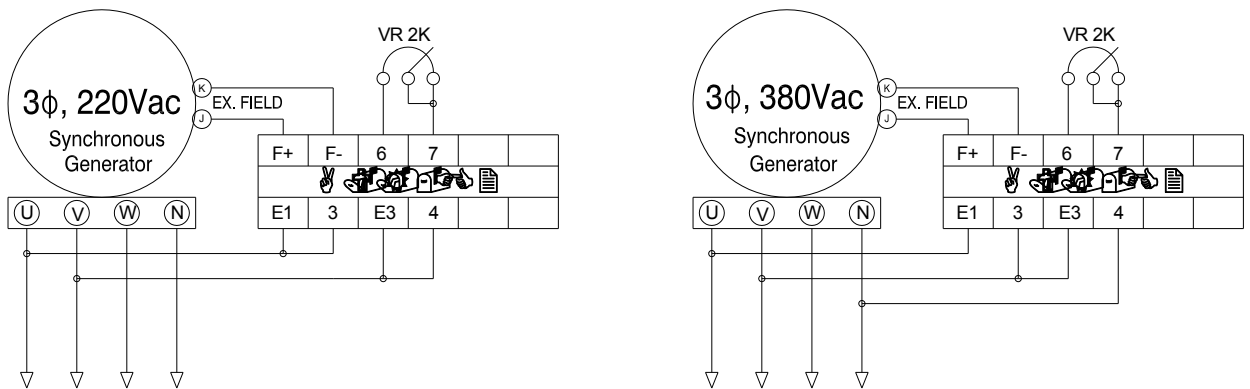

[ Drawing 1 ]



**Warning**

Make sure that AC220V should be supplied to the terminal3, 4

## 8. Check for operation

- 8.1. Check again it is suitable with the generator capacity
- 8.2. Check it fastens tight.
- 8.3. Check if connection with the generator is correct.
- 8.4. Turn voltage regulator resistance(VOLT. in AVR) counterclockwise to maximum.
- 8.5. When using external voltage control resistor, turn it to neutral. Otherwise short terminal 6,7.
- 8.6. According to a generator, turn frequency setting switch on. Do not adjust frequency control resistance. Let it be like as set in a factory.
- 8.7. Turn stability control resistance to neutral and turn stability setting switch off.

## 9. Adjusting

### 9.1. Voltage stability adjusting

- (1) Start up the engine and adjust it to rated voltage and speed.
- (2) Turn stability adjusting resistance(STAB.) clockwise slowly until when voltage is unstable. And turn it counterclockwise little bit.
- (3) Check whether response characteristic comes out by rated loading.
- (4) If satisfactory response characteristic didn't comes out, try again with stability adjusting switch on.
- (5) Usually a stability adjusting switch is used for mass generator.

### 9.2. Frequency adjusting

- (1) According to frequency of generator, put a frequency setting switch on
- (2) Turn frequency adjusting resistance counterclockwise to maximum.
- (3) Start up the engine and adjust it to rated voltage.
- (4) Control engine speed to the frequency which is supposed to be controlled to low frequency.
- (5) Steadily turn UFR resistance clockwise until when generator voltage starts to drop(when UFR LED lamp lighting)
- (6) Control the engine to rated speed.

### 9.3. Over excitation break adjusting

- (1) It is a function stopping generator by shutting off AVR output when exciter field voltage rises over set point.
- (2) There are two actions. First, power generates for 10secs under 240Vdc. Delayed time is getting shorter as voltage goes higher. Second, when output goes over 240Vdc, AVR shut off output instantly.
- (3) When AVR stops to return to normal, the engine should be stopped or AVR's input should be lower than 6Vac for over 2 secs.
- (4) Start up the engine and adjust it to rated voltage and speed
- (5) Apply rated loading to generator
- (6) Measure AVR output voltage.
- (7) To operate over voltage break adjusting resistance(OVX) at low voltage, turn it counterclockwise.

## 10. System Start-up

- 10.1. Start up the engine and drive it at rated speed
- 10.2. Check whether voltage is established.
- 10.3. If voltage is not established, disconnect F+ and F-wires and connect them to battery (+) and (-). And check again the generator voltage is established.
- 10.4. If generator residual voltage is lower than 10 Vac, set an early exciter circuit like below [drawing2]

**Caution**

Set early excitation short. When 24V battery is connected to the field without a R1 resistance and D1 diode, that could cause overvoltage. .

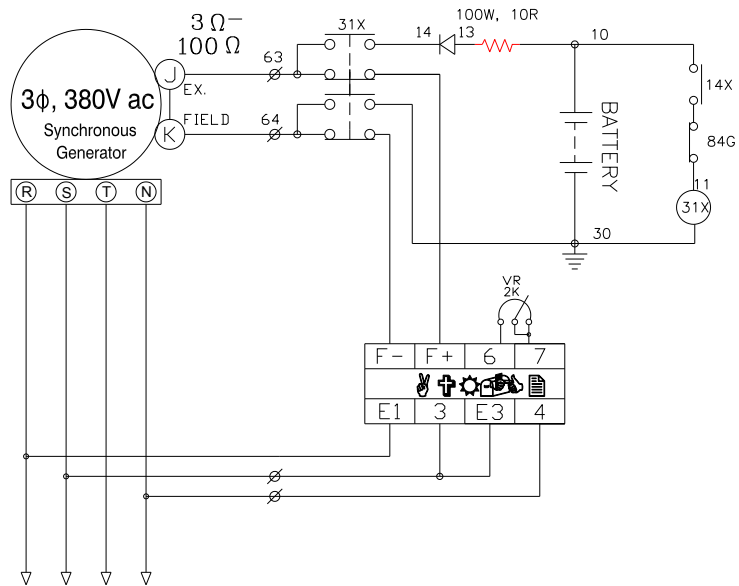

[ Drawing 2 ]

### 11. AVR operation test

- 11.1. Connect wires like below [Drawing3]
- 11.2. A incandescent lamp does not exceed 100W.
- 11.3. Voltage is 220Vac 50hz or 60hz
- 11.4. Turn voltage control resistance clockwise slowly to the maximum. The incandescent lamp is on.
- 11.5. When turning voltage control resistance counterclockwise slowly, the incandescent lamp is off.
- 11.6. At the point of lamp turning off, if turning the resistance clockwise little bit, the incandescent lamp is on and the lamp is off when turning it counterclockwise little bit. If it works, AVR is normal.

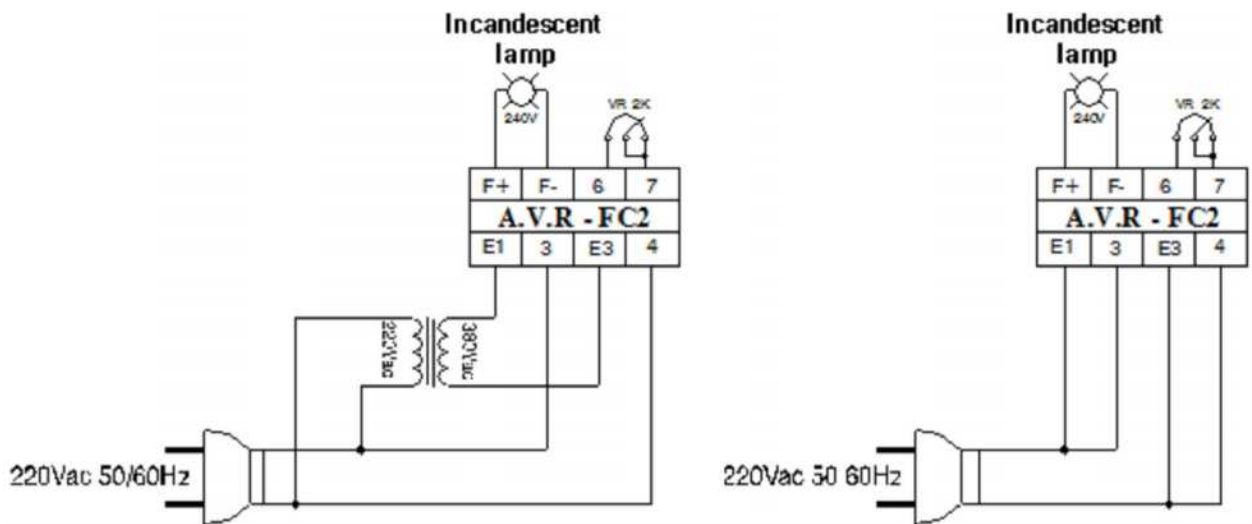

[ Drawing 3 ]

### 12. Frequency–output voltage characteristic curve according to frequency system

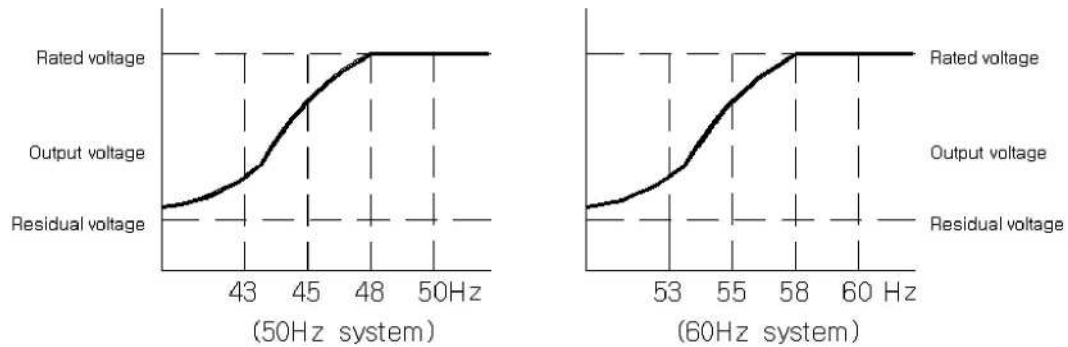

[Frequency–output voltage characteristic curve]

### 13. Trouble causes and solutions.

Symptom	Cause	Solution
Generator output voltage is below 30Vac. (Line voltage)	No residual voltage in the generator	Set an early exciter circuit referring [Drawing2]
	AVR fuse is burnt out	Replace the fuse with a same capacity one.
	Disconnected wire or incorrect connection	Correct wiring work referring circuit diagram.
Generator output voltage is over 50Vac and not adjustable.(Line Voltage)	Terminal6 and 7 are not connected.	If external variable resistance is not connected, connect the terminal6 and terminal7 with a short bar.
	Generator speed is not sufficient so frequency is lower than standard.(UFL LED lighting)	Control generator speed to make out rated frequency..
	Incorrect wire connection	Correct wiring work referring circuit diagram.
Generator output voltage is over 400Vac and not adjustable.(Line Voltage)	A jumper on backside is removed and voltage detector connects with 220V.	If the jumper is removed, connect it with 380V.
	Incorrect wire connection	Correct wiring work with the circuit diagram.
Hunting occurs	Generator is not matched with answering speed	At first, adjust STAB variable resistance. If Voltage is still unstable, turn STAB deep switch on and adjust stability with STAB variable resistance.



ENGINE, GENERATOR CONTROL ENTERPRISE

# EGCON<sup>®</sup>

## 엔진, 발전기 제어 전문기업

### PRODUCTS ITEM

- AVR / 자동전압조정기
- ABC / 자동발전기충전기
- GCU / 발전기제어장치
- ECU / 엔진제어장치
- ESD / 엔진속도검출기
- EPD / 엔진보호장치
- SCR / 동기검출기
- BCU / ACB 제어장치
- ACU / ATS 제어장치
- MPU / 속도검출센서
- GCP / 발전기 운전반
- ECP / 엔진 운전반
- ATS / ATS 운전반
- FGP / 별치형 운전반



AVR  
MODEL : 635/631



ABC  
MODEL : SMP



ABC  
MODEL : SMF



ECU  
MODEL : DG1



GCU  
MODEL : MP2



DMM  
MODEL : 961



ACU  
MODEL : MP3



ETS  
MODEL : Y, B TYPE



## 이지콘(주)

경기도 부천시 오정구 내동 182-3번지 (421-806)

홈페이지 : <http://www.egcon.co.kr>, 이메일 : [sales@egcon.co.kr](mailto:sales@egcon.co.kr)

TEL : 032-677-9806, FAX : 032-677-9807