	Manual of DMM	Doc. No.	EGP-06-04-01
		Written	2006, 04, 14
	961	Page No.	1 / 17

1. Warning

Only licensed technicians or operators can install, control and operate this product in order to prevent injuries or damage of the equipment.

Be sure to read the instruction prior to installation.

2. Notice

Experiment equipment that uses high voltage cannot be used.

Improper use can damage the equipment's parts.

Be sure to check if both input and operation power turns off before connecting or disconnecting DMM.

When current is applied to primary CT, secondary CT should not be open.

If DMM's setting is different from connection method, DMM may display false information.

3. Major functions

3.1. measuring range and accuracy

Measuring items	Measuring range	Measuring accuracy	Remarks
V(voltage)	0~99999(above quadruple * 1k lamp on)	± 0.5%	
A(current)	0~99999(above quadruple * 1k lamp on)	± 0.5%	
Hz(frequency)	45 ~ 65Hz	± 0.5%	
kW	0~99999kW(above quadruple * 1k lamp on)	± 1%	
kVAR	0~99999kVAR(above quadruple * 1k lamp on)	± 1%	
kVA	0~99999kVA(above quadruple * 1k lamp on)	± 1%	
kWh	0~99999kWh(above quadruple * 1k lamp on)	± 1%	
kVARh	0~99999kVARh(above quadruple * 1k lamp on)	± 1%	
Temperature	15 ~ 99℃	± 3%	

3.2. Display a wrong connection by checking input.

3.3. Users can easily check the communication condition via lamp.

3.4. If the temperature is above the set one, lamp turns on and relay contact point is output.

3.5. It is possible to check operation time

4. Basic data

4.1. operation power: AC 85 ~ 265, DC100 ~300

4.2. voltage input: between phases under AC 350V (L-n), normal 230Vac
Between lines under AC 600V (L-L), normal 400Vac

4.3. current input: under AC 8.5A, normal 5Aac

	Manual of DMM	Doc. No.	EGP-06-04-01
	961	Written	2006, 04, 14
		Page No.	2 / 17

4.4. Structure

4.4.1. Size: W96 * H96 * 101 (mm)

4.4.2. PANEL CUT - W91*H91

5. Configuration

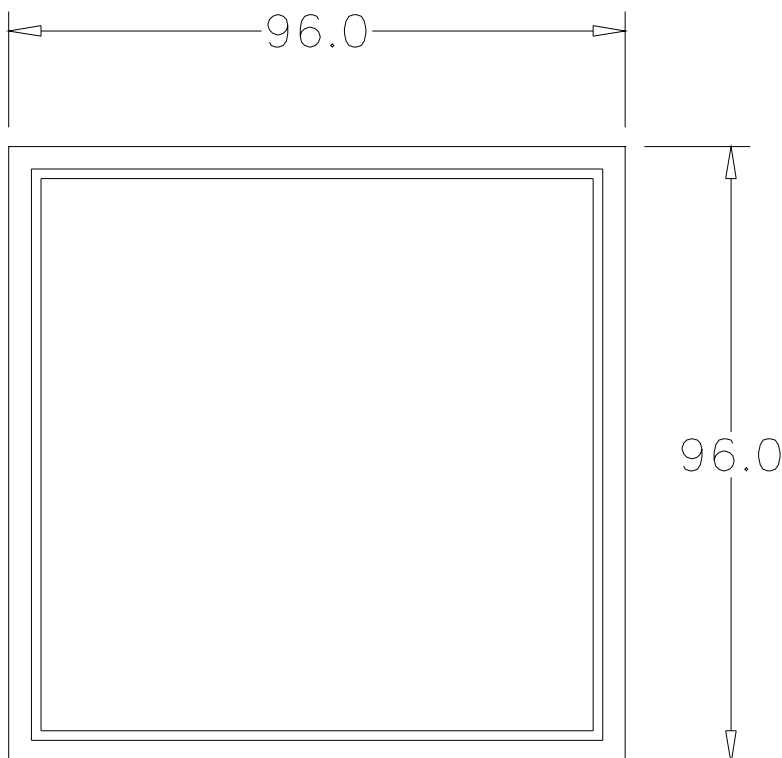
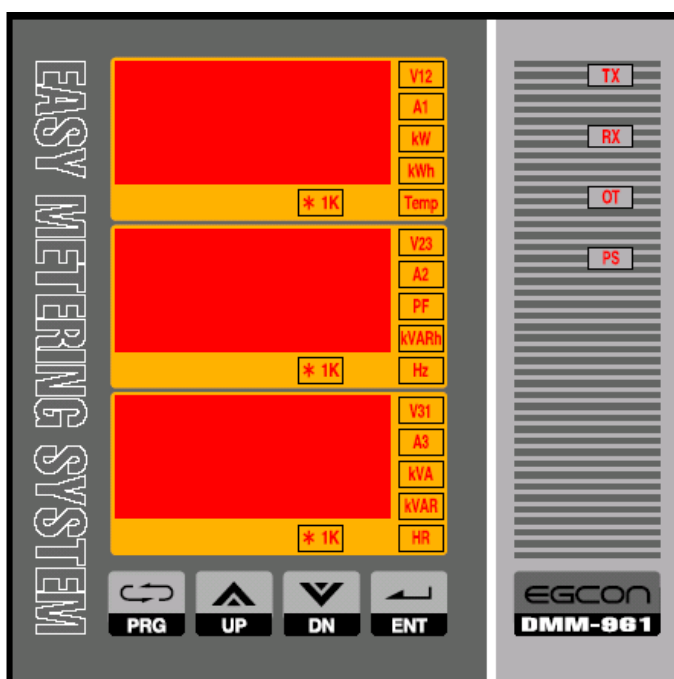



Manual of DMM

Doc. No. EGP-06-04-01

Written 2006, 04, 14

961

Page No. 3 / 17

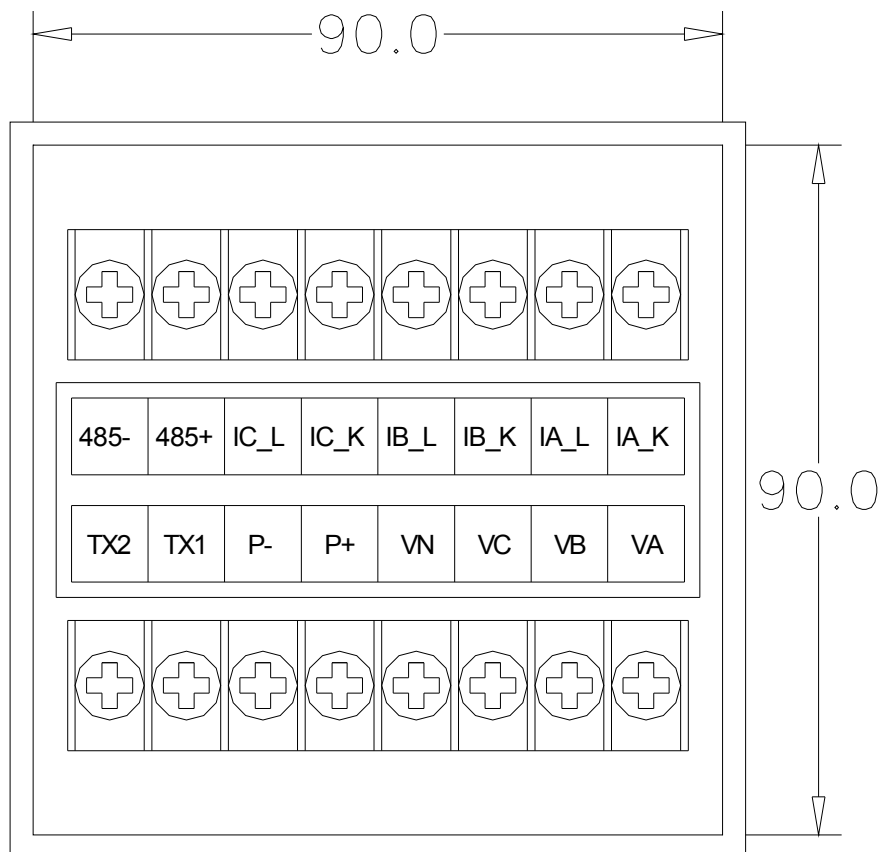
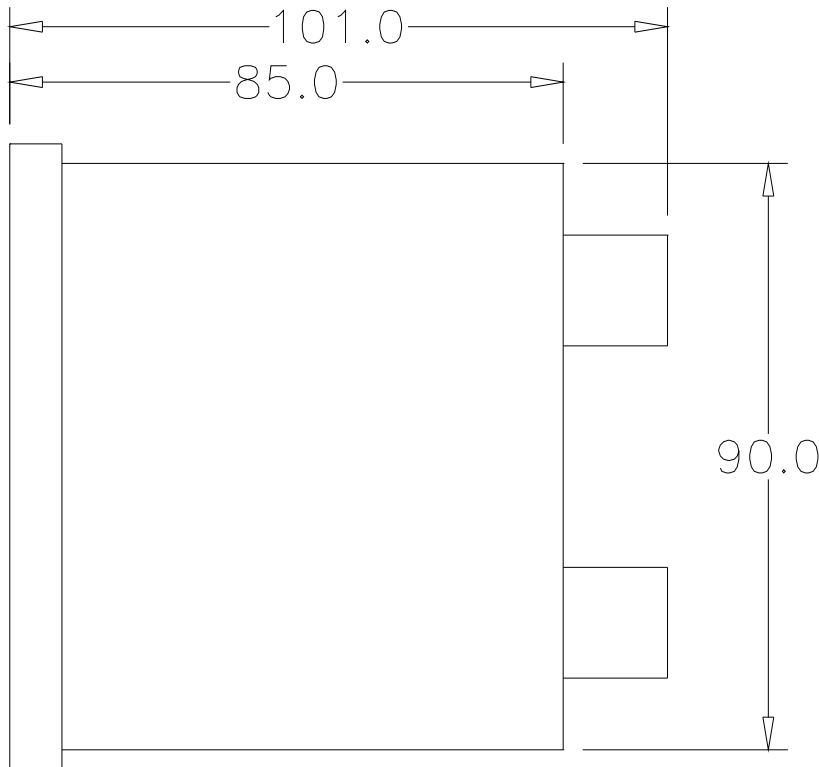

	Manual of DMM	Doc. No.	EGP-06-04-01
		Written	2006, 04, 14
	961	Page No.	4 / 17

6. Lamp explanation

- 6.1. V12, V23, V31: display between phases and between lines voltages depending on setting
- 6.2. A1, A2, A3: display current on each phase
- 6.3. Hz: display frequency when selecting
- 6.4. kW: display valid power when selecting
- 6.5. kWh: display valid power volume when selecting
- 6.6. PF: display power factor when selecting
- 6.7. PF: display invalid power when selecting
- 6.8. kVARh: display invalid power volume when selecting
- 6.9. kVA: display volt ampere
- 6.10. Temp: display temperature when selecting
- 6.11. HR: display working hours when selecting
- 6.12. TX, RX: in communication, lamp turns on
- 6.13. OT: lamps turn on when temperature goes above the set one
- 6.14. PS: lamps turn on in case of wrong connection
- 6.15. *1k: lamps are lit up when indication value is over quadruple-digit

7. S/W explanations

- 7.1. PRG: used when changing setting
If users put this button for more than three seconds, it will be switched to the mode where setting change is available.
- 7.2. Up: Used when changing set point and indication value
- 7.3. DN: Used when changing set point and indication value
- 7.4. ENT: used when selecting setting articles in case of setting change

8. Input/output terminal lineup

- 8.1. P+, P- : action power input terminal (AC 85~265, DC 100~300V)
- 8.2. VA: Voltage A-phase input terminal
- 8.3. VB: Voltage B-phase input terminal
- 8.4. VC: Voltage C-phase input terminal
- 8.5. VN: Voltage N-phase input terminal
- 8.6. IA_K: Current A-phase input terminal
- 8.7. IA_L: Current A-phase output terminal
- 8.8. IB_K: Current B-phase input terminal
- 8.9. IB_L: Current B-phase output terminal
- 8.10. IC_K: Current C-phase input terminal
- 8.11. IC_L: Current C-phase output terminal
- 8.12. 485 +, 485 -: RS485 communications terminal



Manual of DMM







961

Doc. No. EGP-06-04-01

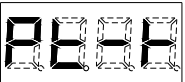
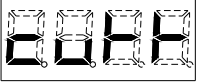
Written 2006, 04, 14

Page No. 5 / 17

9. Basic setting items

Setting items	Segment indication	Setting range	Initial value(■)	Remarks
Connection method	 CONNECTION	1P2D		
		1P3D		
		3P3T		
		3P3D		
		3P4T		
		3P4D	■	
PT ratio	 PT- T	110	■	
		220		
		380		
		440		
		460		
		480		
		3300		
		6600		
		11kV		
22,9kV				
CT ratio	 CURRENT	0 ~ 5000	10	
Communications Speed	 BAUD RATE	2400		
		4800		
		9600	■	
		19200		
Communications Address	 ADDRESS	0 ~ 255	1	
Voltage Indication	 VOLT	L- L	■	
		L- n		
Indicated Time	 SCROLL	0 ~ 10sec	0	
Temperature Setting	 TEMP SET	15 ~ 90	50	

	Manual of DMM	Doc. No.	EGP-06-04-01
	961	Written	2006, 04, 14
		Page No.	6 / 17

10. Connection Method

10.1. 3-phase 4-line type direct connection

10.1.1. Conn 3P4D Setting

10.1.2. between lines voltage AC 380V (MAX AC 600V), It is possible to be connected to rated current 5A

10.1.3. Connected method

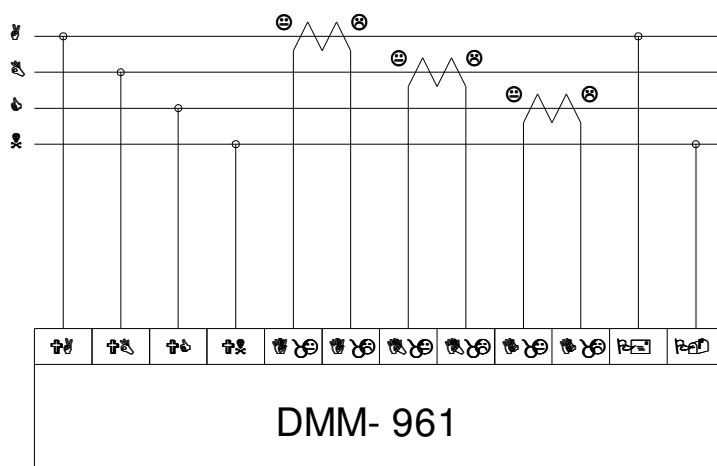

3상4선 직접연결

3-phase 4-line direct connection

10.2. 1-phase 2-line type direct connection

10.2.1. Conn 1P2D Setting

10.2.2. connection method

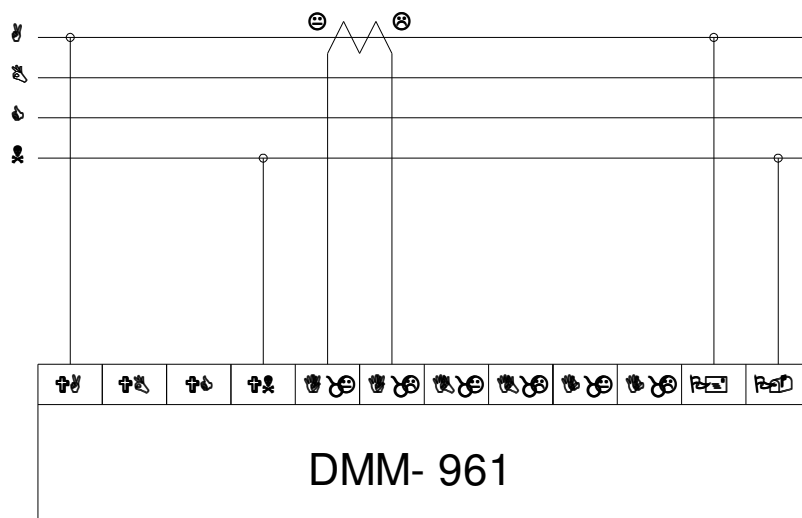

1상2선 직접연결

1-phase 2-line direct connection



Manual of DMM

961

Doc. No.	EGP-06-04-01
Written	2006, 04, 14
Page No.	7 / 17

10.3. 1-phase 3-line type direct connection

10.3.1. Conn 1P3D Setting

10.3.2. Connection method

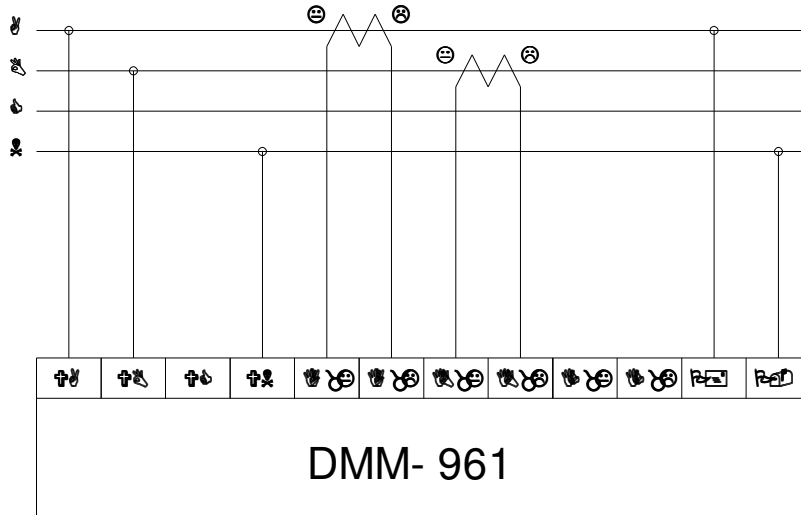

1상3선 직접연결

1-phase 3-line direct connection

10.4. 3-phase 3-line type direct connection

10.4.1. Conn 3P3D Setting

10.4.2. Connection method

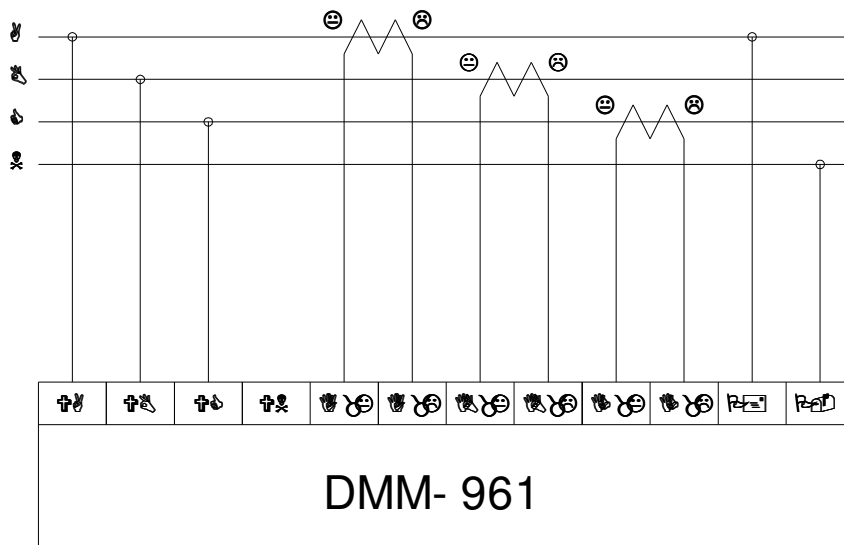

3상3선 직접 결선

3-phase 3-line direct connection



Manual of DMM

Doc. No.

EGP-06-04-01

Written

2006, 04, 14

961

Page No.

8 / 17

10.5. 3-phase 3-line type PT connection

10.5.1. Conn 3P3t setting

10.5.2. Connection method

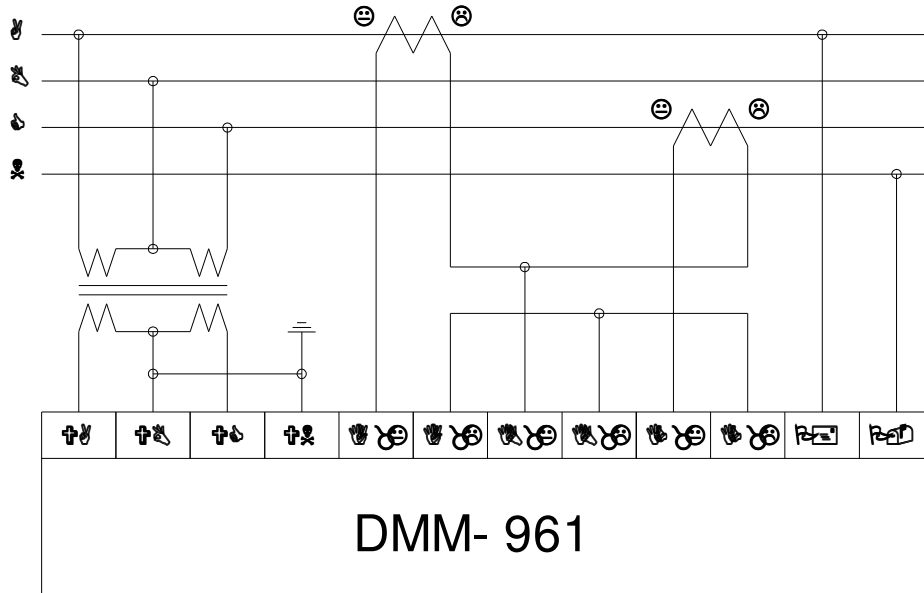

3상3선 PT 결선

3-phase PT connection

10.6. 3-phase 4-line type PT connection

10.6.1. Conn 3P4t setting

10.6.2. Connection method

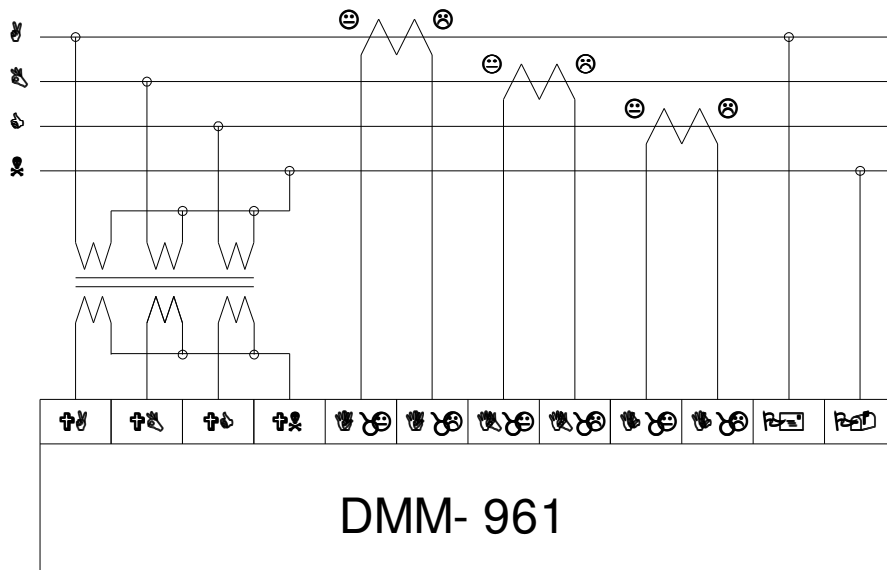

3상4선 PT 결선

3-phase 4-line PT Connection

	Manual of DMM	Doc. No.	EGP-06-04-01
	961	Written	2006, 04, 14
		Page No.	9 / 17

11. Method of setting change

11.1. Connection method change

11.1.1. Press the key "PRG" for more than three seconds

11.1.2. "conn" appears at the first line as follows

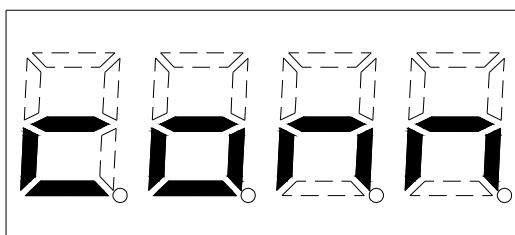

CONN

11.1.3. Displays at the second line as follows.

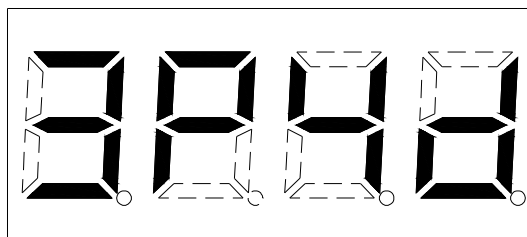

3P4D

11.1.4. Press the key "ENT" to change the setting

11.1.5. In turn, "conn" at the first line blinks

11.1.6. Choose the preferred connection method by using the key "Up, Dn"

11.1.7. select by pressing the key "PRG".

11.1.8. Choose "End" at the second line by using the key "Up, Dn"

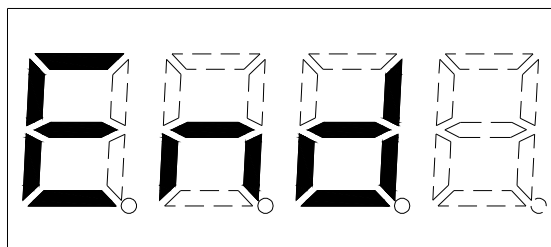

End

11.1.9. Get out of setting by pressing the key "ENT"

11.1.10. 결선 방식 표시

- 1상 2선식 직접 연결 : 1P2D

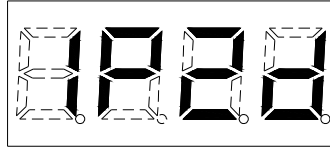

1P2D

- 1상 3선식 직접 연결 : 1P3D

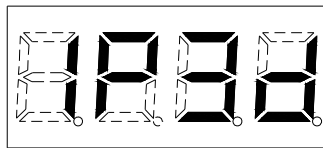

1P3D

- 3상 3선식 직접 연결 : 3P3D



3P3D

- 3상 3선식 PT 연결 : 3P3t



3P3T

- 3상 4선식 PT 연결 : 3P4t



3P4T

- 3상 4선식 직접 연결 : 3P4D



3P4D

	Manual of DMM	Doc. No.	EGP-06-04-01
	961	Written	2006, 04, 14
		Page No.	11 / 17

11.2. Change of CT ratio

11.2.1. Press the key "PRG" for more than three seconds

11.2.2. Use the key "Up, Dn" so that the following indication appears at the first line

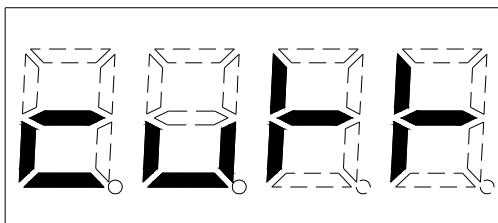

CURRENT

11.2.3. In turn, the following indication appears at the second line.

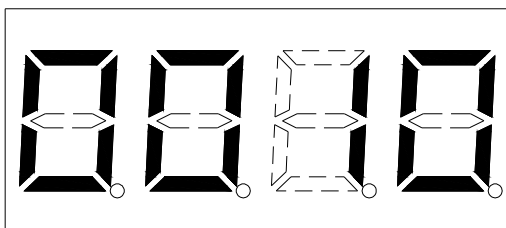

10

11.2.4. The current condition is set as 50A primary current ratio and secondary 5A CT ratio

11.2.5. Press the key "ENT" to change CT ratio to 100/5A

11.2.6. The first line blinks

11.2.7. Set the number at the second line to 20 by using the key "UP"

11.2.8. Press and make a choice the key "PRG"

11.2.9. Select "End" at the second line by using the key "Up, Dn"

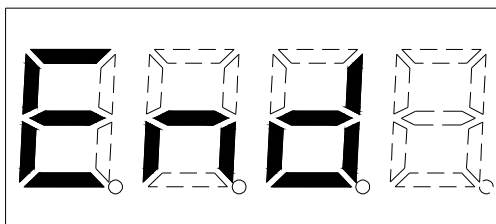

End

11.2.10. get out of setting by pressing the key "ENT".

11.2.11. CT ratio is fixed at 5A

11.2.12. It is possible to set CT ratio from 5/5A to 25000/5A

11.2.13. It is possible to change from 1 to 5000

11.3. Change of PT ratio

11.3.1. Press the key "PRG" for more than three seconds

11.3.2. **Up, Dn** 키를 이용하여 첫 번째 줄 에 다음 과 같이 표시되게 선택한다.

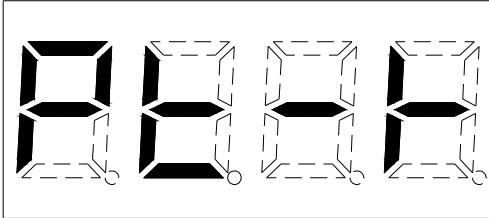

PT- T

11.3.3. 두 번째 줄에 다음과 같이 표기된다.

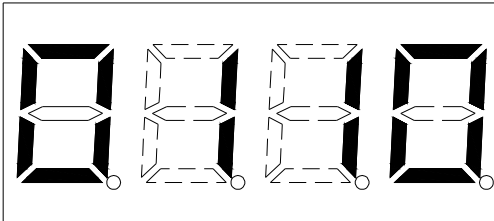

110

11.3.4. Change PT ratio to 480

11.3.5. Press the key "ENT"

11.3.6. PT-t at the first line blinks.

11.3.7. Change the second to 480 by using the key "Up, Dn"

11.3.8. Select by pressing the key "PRG"

11.3.9. make a choice of "End" at the second line by using the key "Up, Dn"

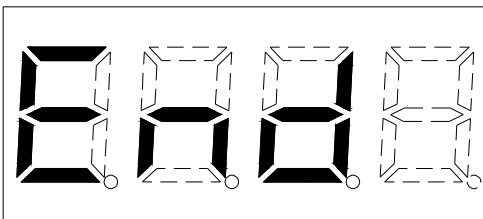

End

11.3.10. Get out of setting by pressing the key "ENT"

11.3.11. PT ratio is applied only when setting connection method as 3P3T, 3P4T

11.3.12. Overlooked when using other connection methods

11.3.13. The secondary is fixed at 110V between-line voltage

	Manual of DMM	Doc. No.	EGP-06-04-01
	961	Written	2006, 04, 14
		Page No.	13 / 17

11.3.14. PT ratio selecting voltage

- 110

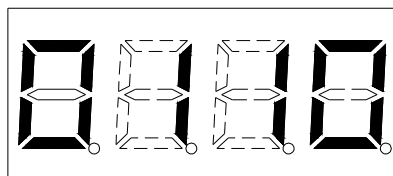

110

- 220



220

- 380

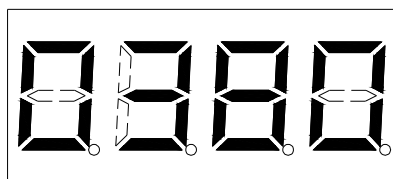

380

- 440

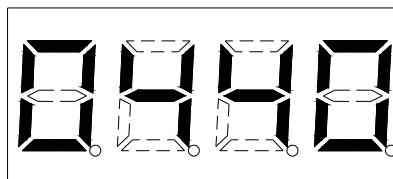

440

- 460



460

- 480

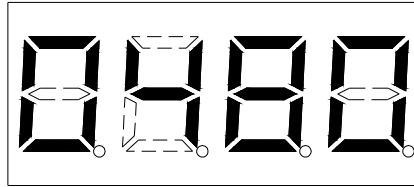

480

- 3300

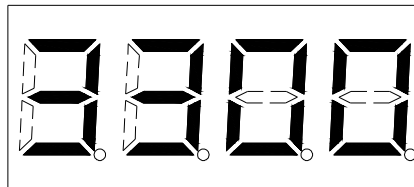

3300

- 6600

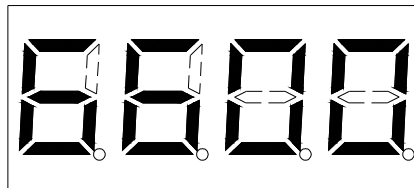

6600

- 11,000 (11kV) : * 1k에 점등됨

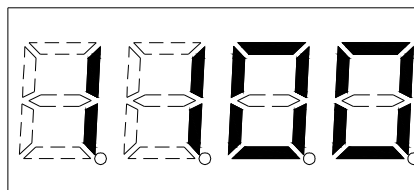

11.0K

- 22,900 (22.9kV) : * 1k에 점등됨

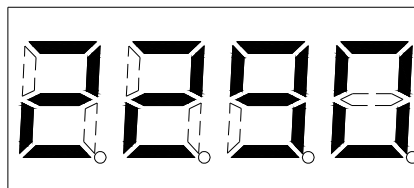

22.9K

	Manual of DMM	Doc. No.	EGP-06-04-01
	961	Written	2006, 04, 14
		Page No.	15 / 17

11.4. Scroll time setting

11.4.1.

11.4.2. It is possible to choose from 0 to 10 seconds. If selecting 0, it is fixed.

11.4.3. The first line is indicated

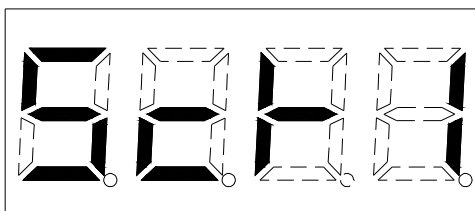

SCROLL

11.4.4. It is possible to choose value from 0 to 10 in case of the second line

11.4.5. It is set as 0.

11.5. Temperature setting

11.5.1. When the indoor temperature is above the set temperature, OT lamp turns on

11.5.2. Connection point of TX1 and TX2 of the terminal closes

11.5.3. The first line will be indicated.

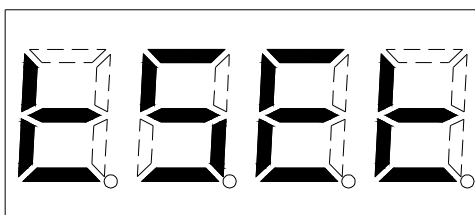

TEMP SET

11.5.4. it is possible to choose value from 15 to 90C

11.5.5. It is set as 50C.

11.6. Communications speed setting

11.6.1. RS 485 communications speed setting

11.6.2. The first line will be indicated

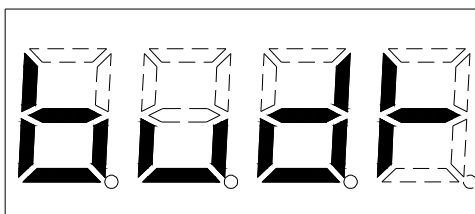

BAUD RATE

11.6.3. It is possible to choose one from 2400, 4800, 9600, 19200 at the second line

11.6.4. In case of 19200, 1920 display and lamp turns on *1K

	Manual of DMM	Doc. No.	EGP-06-04-01
	961	Written	2006, 04, 14
		Page No.	16 / 17

11.7. Communication address setting

11.7.1. In case of RS 485 communication, choose address

11.7.2. The first line will be indicated

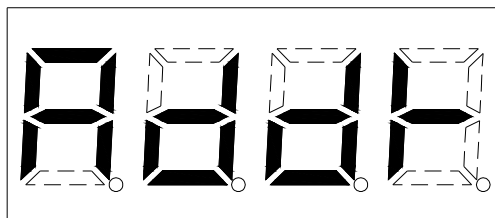

ADDRESS

11.7.3. It is possible to choose from 0 to 255 at the second line

11.8. Voltage indication method

11.8.1. Choose display method of between lines and between phases

11.8.2. Display at the first line

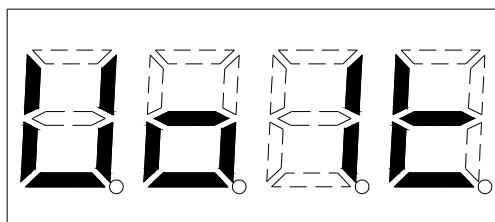

VOLT

11.8.3. In case of the following display at the second line, between lines voltage displays as L-L

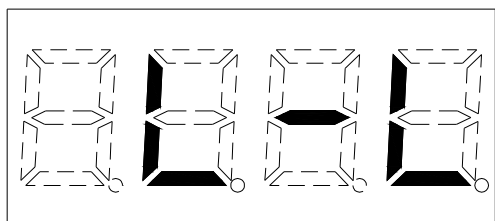

L- L

11.8.4. In case of the following display at the second line, between phases voltage displays as L-n

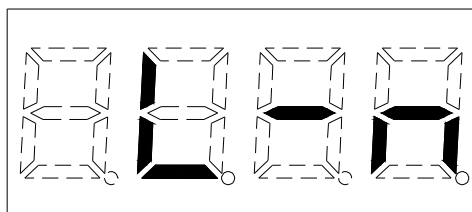

L- N

	Manual of DMM	Doc. No.	EGP-06-04-01
	961	Written	2006, 04, 14
		Page No.	17 / 17

11.9. Program version display

11.9.1. Display of program's current version of DmM-961

11.9.2. Display of the first line

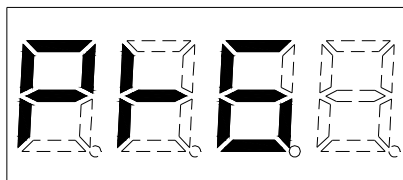

PRG REV

11.9.3. Display of the following at the second line

11.9.4. Version 1.0

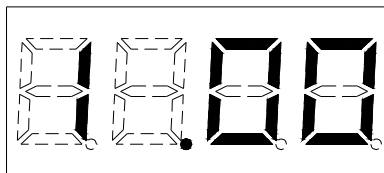

1.00

11.10. Setting items initialization

11.10.1. Initializing DMM-961's setting

11.10.2. Display of the first line



DEFAULT

11.10.3. Display of YES or No at the second line



YES

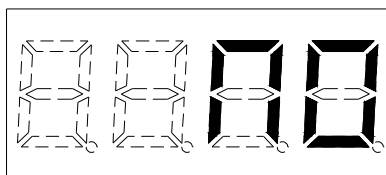

NO